

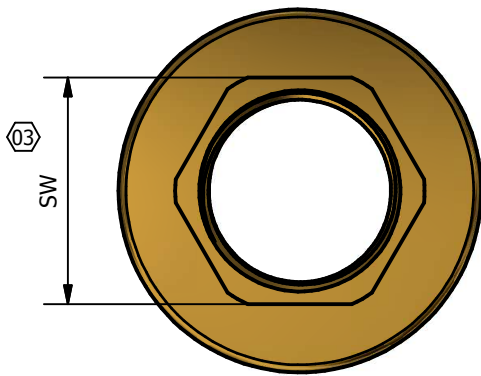

A-A (1 : 1)

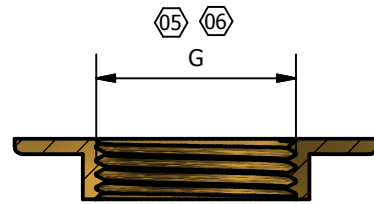
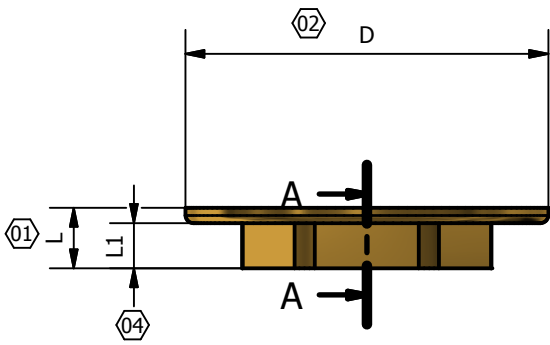

TDM CODE	SIZE	G	D	L	L1	SW
121E 38	3/8	3/8	30	7,5	5,5	20
121E 12	1/2	1/2	40	7,5	5,5	26
121E 34	3/4	3/4	48	8	6	30
121E 01	1"	1"	51,5	9	7	37
121E P4	1"1/4	1"1/4	60	9	7	45
121E P2	1"1/2	1"1/2	68	10,5	8	53
121E 02	2"	2"	75	9	6	64

WORKING PRESSURE MAX from 1/8 to 1"1/4	16 BAR
WORKING PRESSURE MAX from 1"1/2 to 2"	10 BAR
WORKING TEMPERATURE MAX	120°C

CONFORMITY
1) DM 174 del 6 Aprile 2004
2) UNI EN ISO 228

00	Prima emissione	Delaini M.	10/10/2009
Rev.	Nota Revisione	Approvatore	Data Approvazione
Toll Gen:	JS13	Stato sup.:	Giallo Sabbiato
Filetto:	ISO 228	Note tecniche:	
Peso lavorato:	Peso grezzo:	N° stampo:	
Materiale: CW 617N EN12165		Disegnatore: Delaini P.	Data: 10/10/2009
TDM Brass s.r.l via Artigiani , 7-9 25030 Maclodio BS Italy tel +39 030 9972217 fax 030 9787089 www.tdmbrass.it email info@tdmbrass.it			

Codice: 121E scheda

Descrizione: Controdado flangiato-Flanged back nut

TDM BRASS
Italian Fittings